

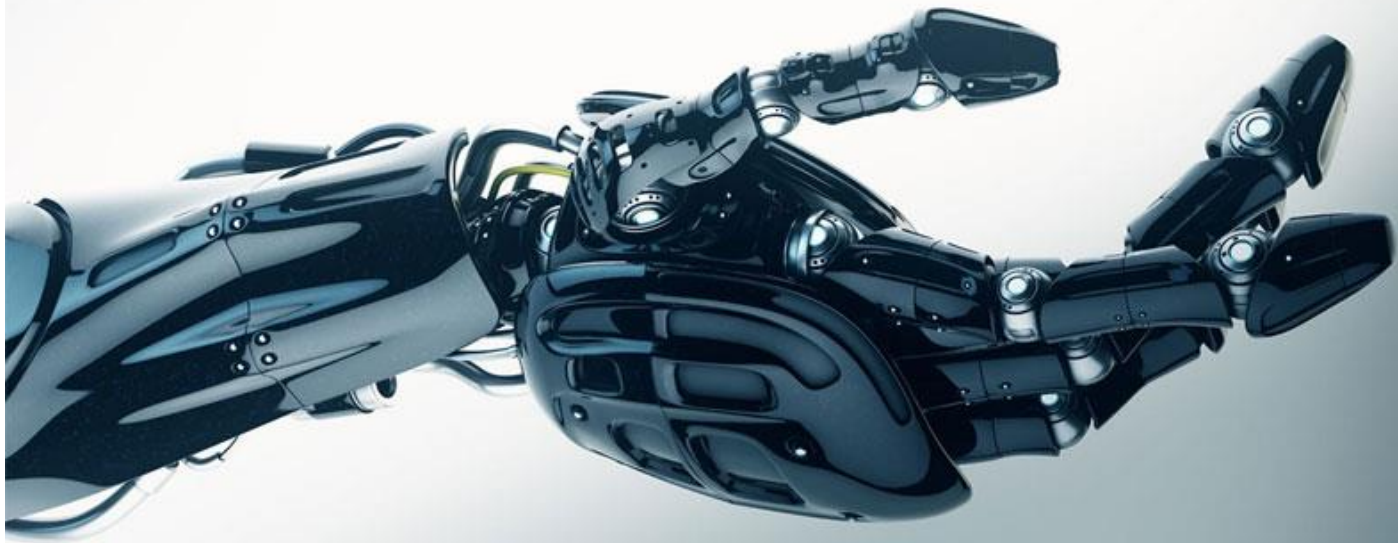

DUY LONG

MECHANICAL TECHNOLOGY



Maintaining your Success

WHAT WE DO

- Automation Machine Manufacturing



DUY LONG
MECHANICAL TECHNOLOGY

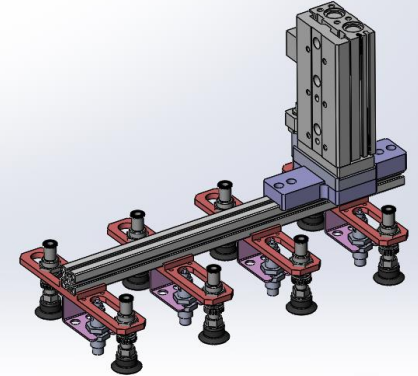
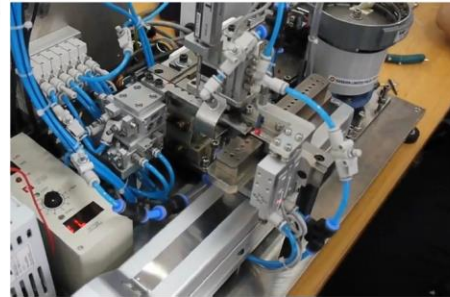
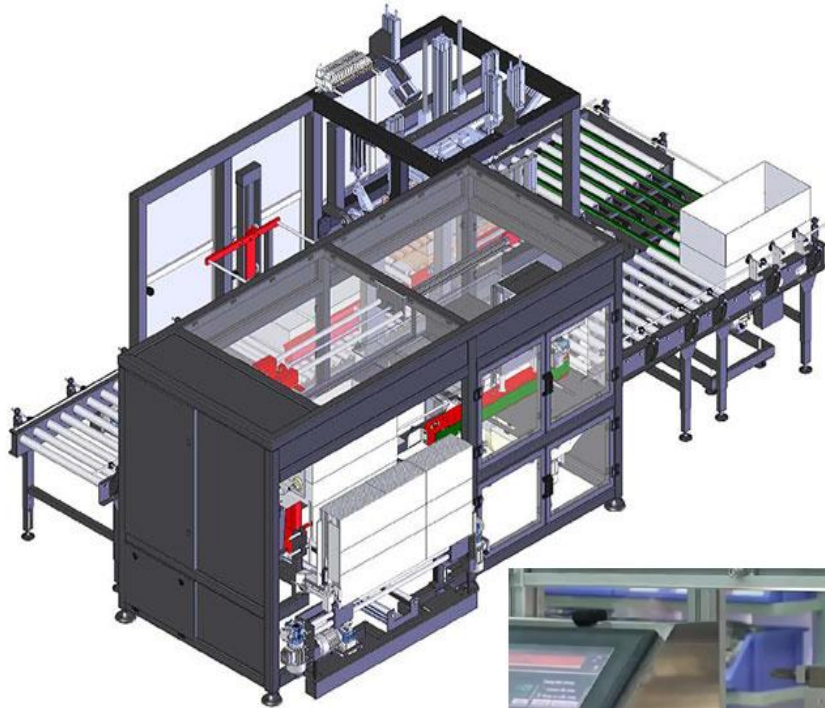

Case Packer Machine can
modify for any type of product



Multi purpose gripper
Designing

SOFT
ROBOTICS

WHAT WE DO

- Automation Machine Manufacturing



DUY LONG
MECHANICAL TECHNOLOGY

New Technology in Industry
4.0. Vision Sensor



Manufacturing Many
Purpose Conveyor



Machine Vision and
Barcode Reader

WHAT WE DO

Automation Machine Manufacturing - Conveyor



DUY LONG
MECHANICAL TECHNOLOGY



Popup Conveyor



Popup Conveyor

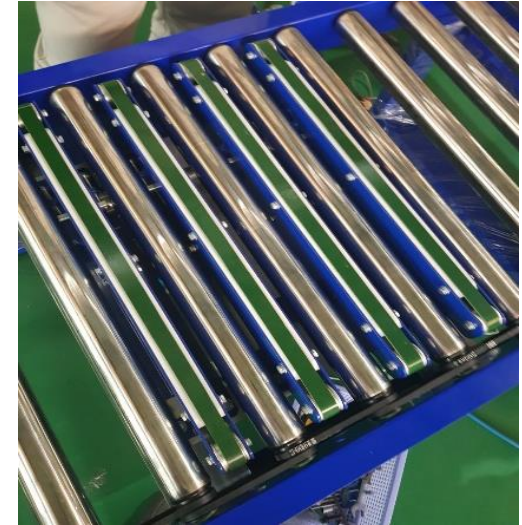

Popup Conveyor Heavy duty



Plastic & Roller Conveyor



Chain Conveyor



Stainless Steel 304 Conveyor

WHAT WE DO

Automation Machine Manufacturing – Supporting System for Plastic Molding



DUY LONG
MECHANICAL TECHNOLOGY



Automatic Part Feeder/Loader & Counting Conveyor for Inject Molding Machine

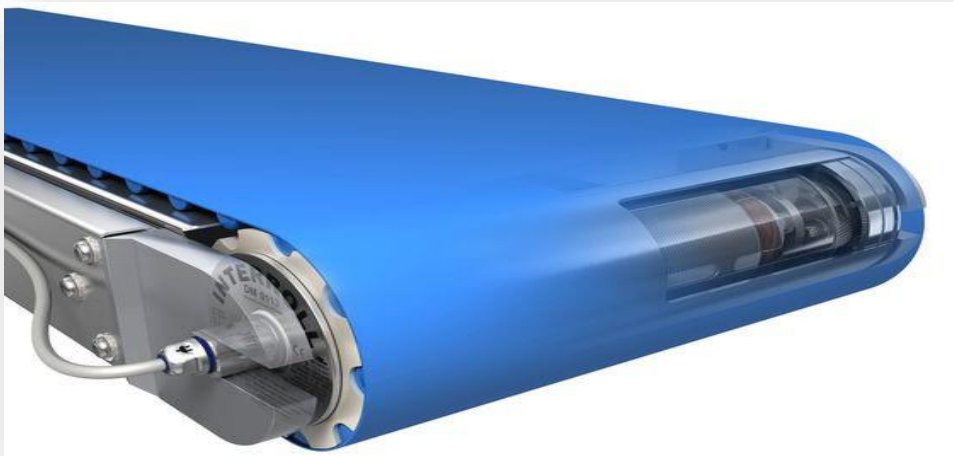

Conveyor Design & Manufacturing



Guide Roller Design

WHAT WE DO

Automation Weighing System – Duy Long Made or Trading with Calibrate Commissioning



DUY LONG
MECHANICAL TECHNOLOGY



WHAT WE DO

AUTOMATIC PALLET CLEANING SYSTEM with LOADER and UNLOADER



DUY LONG
MECHANICAL TECHNOLOGY



Pallet will input 10 pcs 1 time into this system for the cleaning procedure,
After 16s / 1 pallet will done the circle
After that in the unloader station they will be stacked into 10 pcs per column or 6, 4, ...

WHAT WE DO

Checkweighing, Conveyor, Sorting, Rejector

Automation Machine Manufacturing & System Design



DUY LONG
MECHANICAL TECHNOLOGY

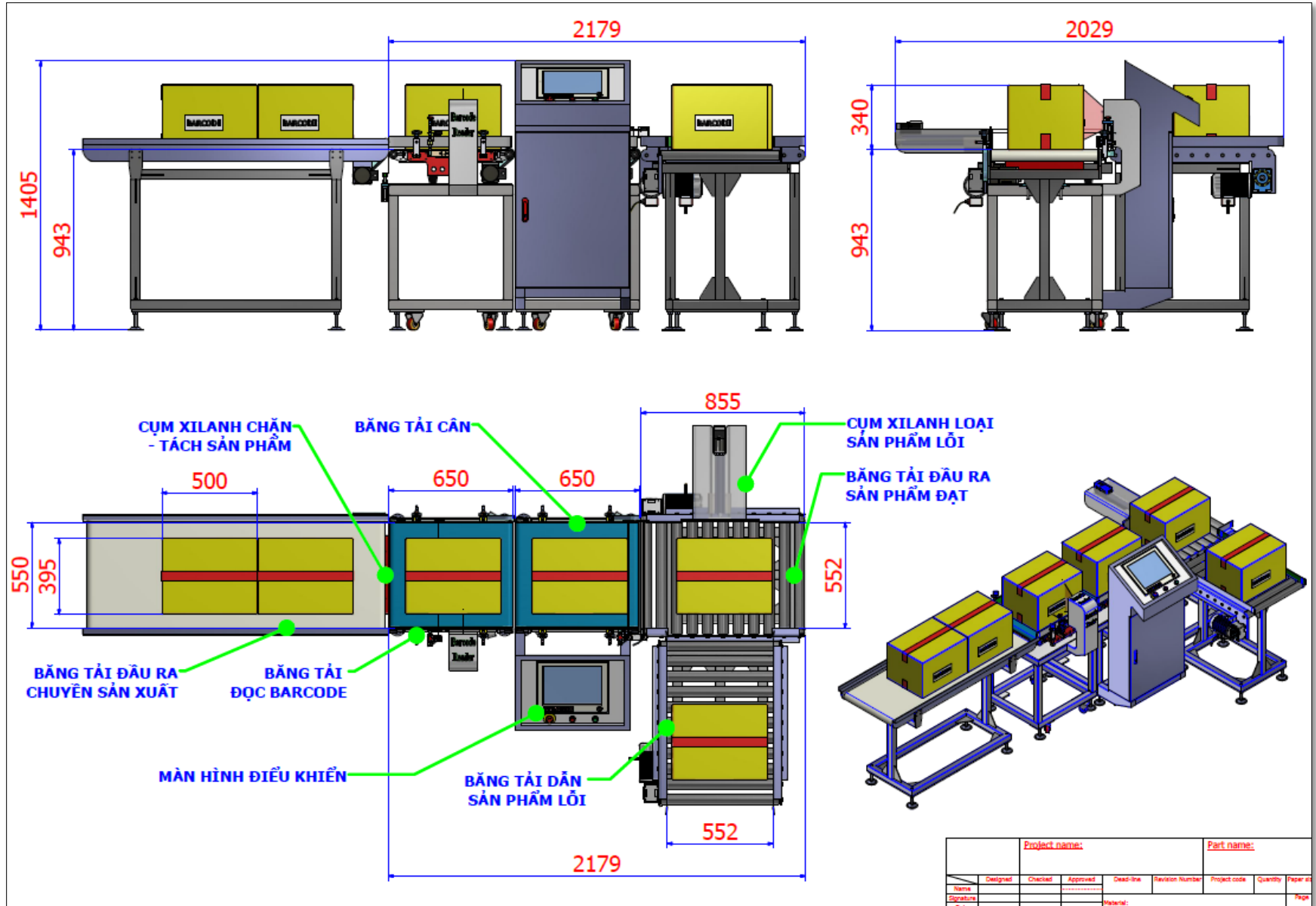

WHAT WE DO

Checkweighing, Conveyor, Sorting, Rejector

Automation Machine Manufacturing & System Design



DUY LONG
MECHANICAL TECHNOLOGY

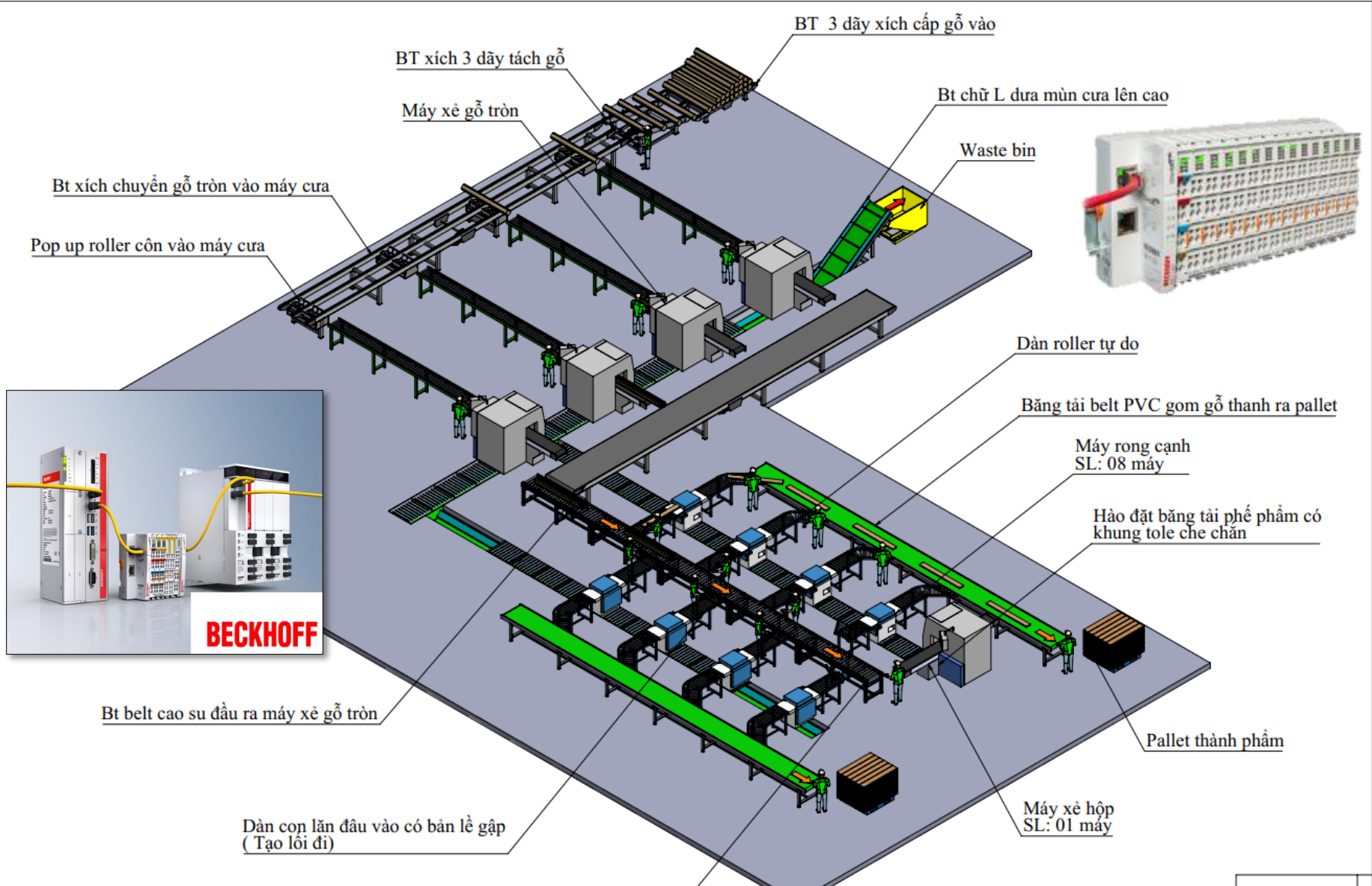

WHAT WE DO

Checkweighing, Conveyor, Sorting, Rejector



DUY LONG
MECHANICAL TECHNOLOGY

Automation Machine Manufacturing:

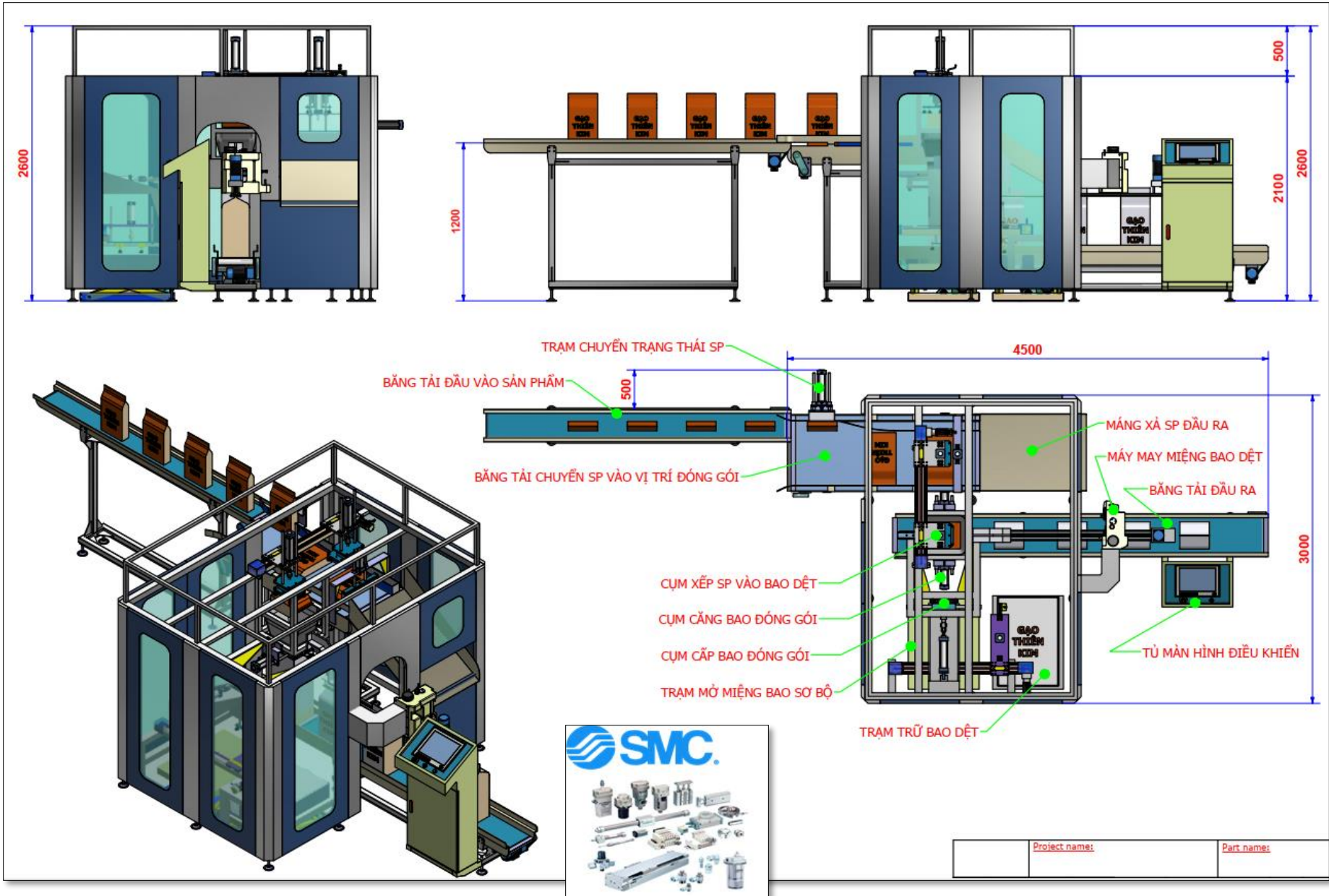

WHAT WE DO

Checkweighing, Conveyor, Sorting, Rejector

Automation Machine Manufacturing



DUY LONG
MECHANICAL TECHNOLOGY

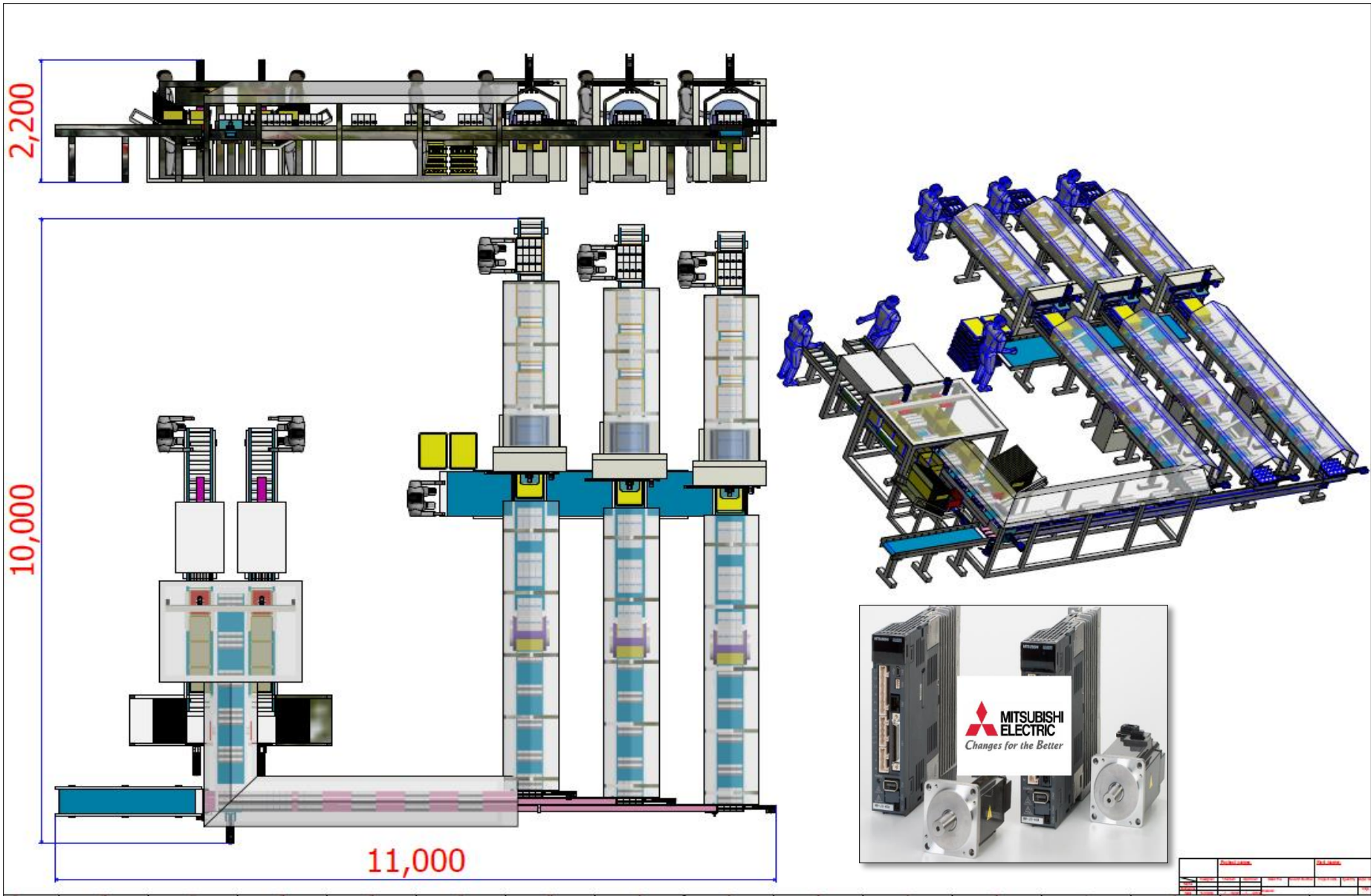

WHAT WE DO

- Electrical boxes manufacturing – with Programming team



DUY LONG
MECHANICAL TECHNOLOGY



Siemens PLC Panel

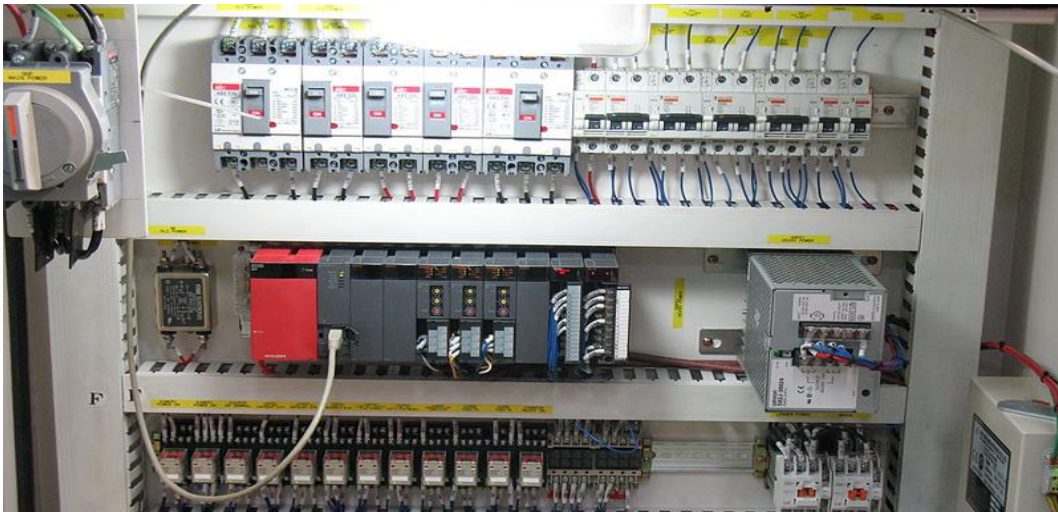

Mitsubishi PLC Panel

Making controlling box and electrical boxes



Inverter Control Panel

WHAT WE DO

- Electrical Box, Valve Control Box



DUY LONG
MECHANICAL TECHNOLOGY

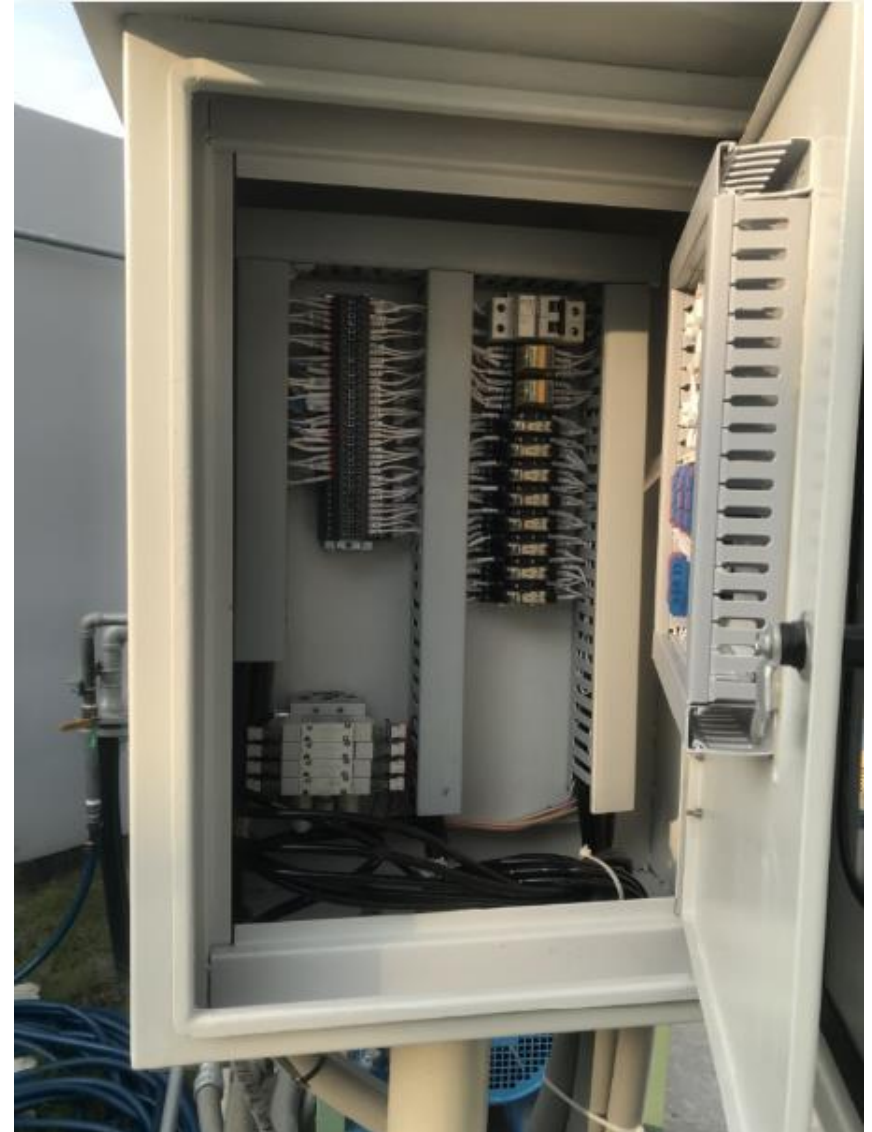

Tủ điều khiển Valve cho nhà máy sx giấy của Nhật – chuẩn IP65



DUY LONG
MECHANICAL TECHNOLOGY



**MECHATRONIC
STORE**

OUR PARTNERS:



OUR PARTNERS are all over the world

OUR PARTNER

10 years working in Automation Spare Parts



DUY LONG
MECHANICAL TECHNOLOGY

FESTO

Pneumatic
automation
& Electric drives



CAMOZZI

Pneumatic
automation



SMC



Parker



OUR PARTNER Spare Part Distribution



DUY LONG
MECHANICAL TECHNOLOGY

OMRON



E2K-X



E3NX



CP1L



CJ1M



NB10W



MX2



R88



MITSUBISHI



WHAT WE DO

Spare Part Distribution



DUY LONG
MECHANICAL TECHNOLOGY



Think Automation and beyond...

Switches, Relays, E-Stop, Button, Indicator



Sản phẩm dùng cho tủ điện của IDEC

- Nút nhấn đèn báo
- Bộ hiển thị
- Nút nhấn khẩn
- Relay
- Biến trở
- Màn hình
- Phụ kiện tủ điện

Các dòng cảm biến của Panasonic

- Cảm biến sợi quang
- Cảm biến Màn an toàn
- Cảm biến vùng
- Cảm biến Quang
- Cảm biến dạng thu gọn
- Sản xuất theo nhu cầu



Fiber Sensors 	Light Curtains / Safety Components 	Area Sensors 
Photoelectric Sensors / Laser Sensors 	Micro Photoelectric Sensors 	Inductive Proximity Sensors 
Particular Use Sensors 	Sensor Options 	Wire-Saving Systems 

OUR PARTNER in ROBOTICS



DUY LONG
MECHANICAL TECHNOLOGY

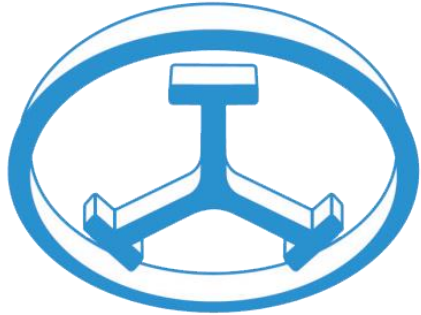

ROBOT 3T

LET'S REALIZE YOUR IDEAS



Range of movement

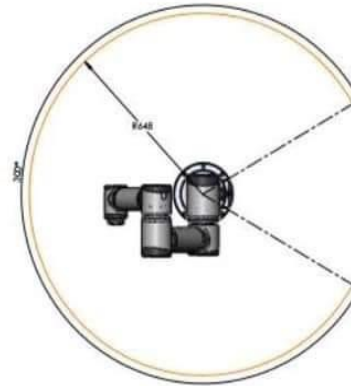
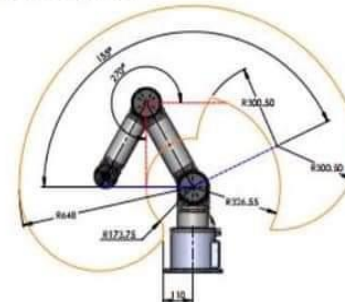

Output flange

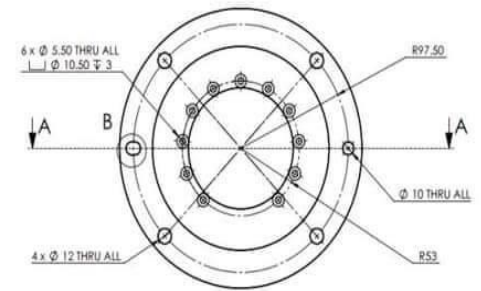

Robot Drawing

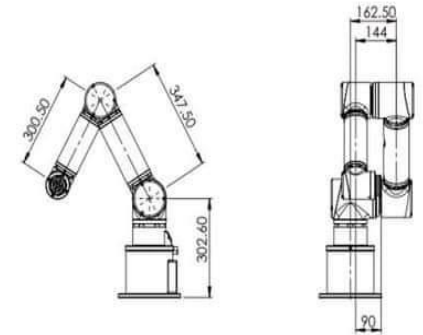

MADE IN VIETNAM ROBOT

OUR PARTNER in ROBOTICS

We are System Integrator



DUY LONG
MECHANICAL TECHNOLOGY



OUR PARTNER in AGV

ESATECH

AGV System with mapping system



WHAT WE DO

ELECTRONICS

Maintenance Services

- **REPAIRING CONTROLLER in CNC MACHINES**



- **REPAIRING CONTROLLER in MULTI AXIS MACHINES:**



Workshop

ASSEMBLY WORKSHOP

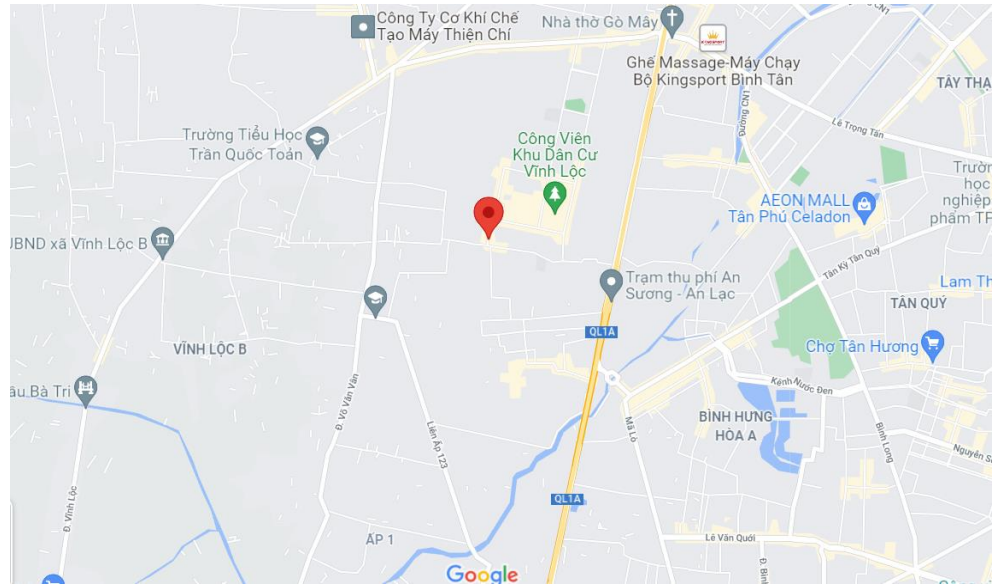

11/2 Bình Thành, Bình Hưng Hòa B, Bình Tân TPHCM

Workshop

Metal Processing Partners



Workshop

Processing manufacturing precision mechanical equipment on CNC machines.



DUY LONG
MECHANICAL TECHNOLOGY



Preferred Customers:

- Technology CNC company
- A My Gia Company.
- Huhtamaki Company.
- Schaeffler Viet Nam Company.
- Camso Viet Nam Company.
- Kimberly Clack Viet Nam Company.
- Sai Gon Precision Company.
- Fujikura Viet Nam Company.

- ❖ AGV | AMR A Series platform là nền tảng di chuyển di động tự động thông minh.
- ❖ Tích hợp công nghệ điều hướng SLAM linh hoạt.
- ❖ Giao diện phần cứng mở rộng phong phú, các hàm chức năng đa dạng giúp dễ dàng tích hợp hầu hết các cơ cấu chấp hành hiện có như băng tải, bàn nâng, robot ...
- ❖ API tích hợp sẵn cho phép kết nối và điều khiển AMR từ các ứng dụng bên thứ 3 như ERP, WMS ...
- ❖ Thiết kế phần cứng cơ khí linh hoạt dễ dàng gá lắp các cơ cấu chấp hành.
- ❖ Chiều cao cơ sở thấp (tối đa chỉ 265mm với loại tải trọng 600kg) phù hợp cho các ứng dụng đòi hỏi chiều cao thấp.
- ❖ Tải trọng đa dạng: Từ 200kg đến 800kg